

PRECAST DECORATIVE BOUNDARY WALL



FS-IMS | SM | FM-02 Version 1.1



Head office:
FUJI Silvertch Concrete Pvt. Ltd.
4th Floor, House No. 5
Magnet Corporate Park
Near Zydus Hospital, S. G. Highway
Thaltej, Ahmedabad 380 054.
Phone: +91 79 4021 0000
Email: info@fujisilvertch.com
Web: www.fujisilvertch.com

Regional offices:
Delhi-NCR, India
Level 18, One Horizon Center, Golf Course Road
DLF Phase-5, Sector 43, Gurgaon 122 002.
Mumbai, India
309, H-2, Western Express Highway
Nav Prabhat Society, Navpada, Vile Parle (E)
Mumbai 400 057.
Vadodara, India
518, K-10 Grand, B/h Atlantis
Sarabhai Campus, Alkapuri Road
Vadodara, Gujarat 390 007.



Please scan the
QR code on your
smartphone to save
the contact details



Decorative Boundary Wall



PRECAST DECORATIVE BOUNDARY WALL

Highly attractive, Reckli-finished, high-strength, precast reinforced cement concrete boundary walls, manufactured with high-performance self-compacting concrete as per Japanese Industrial Standards (JIS). Conforming to Indian Standards and capable of withstanding wind loads. Useful as decorative boundary walls for industries, highways, railways, parks, farmlands and such.

SECTION

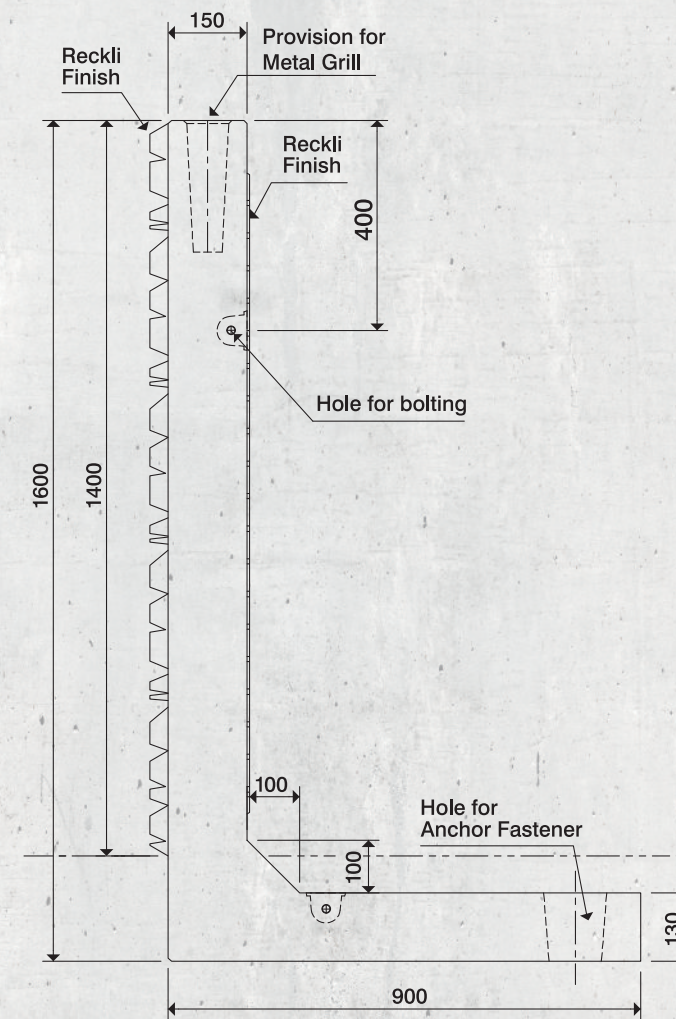

BACK SIDE VIEW

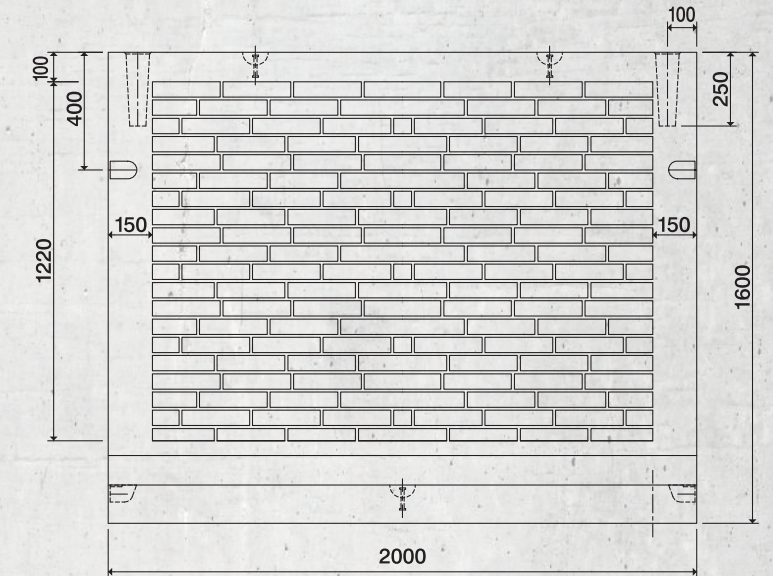

PLAN VIEW

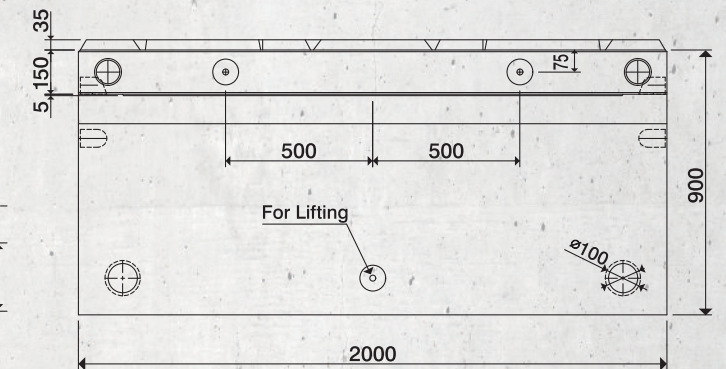

FRONT VIEW



BACK VIEW

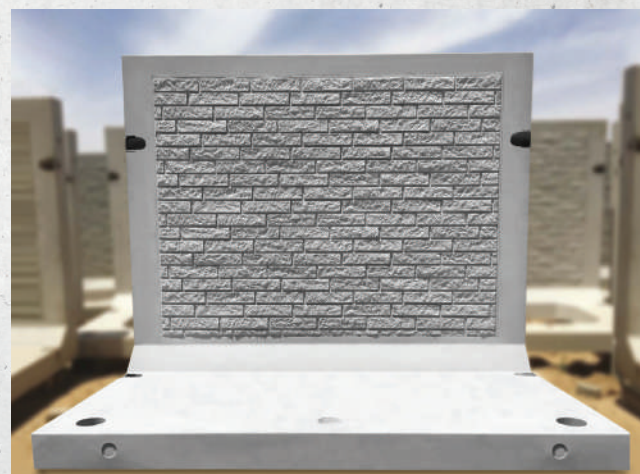

TYPICAL FOUNDATION DETAIL

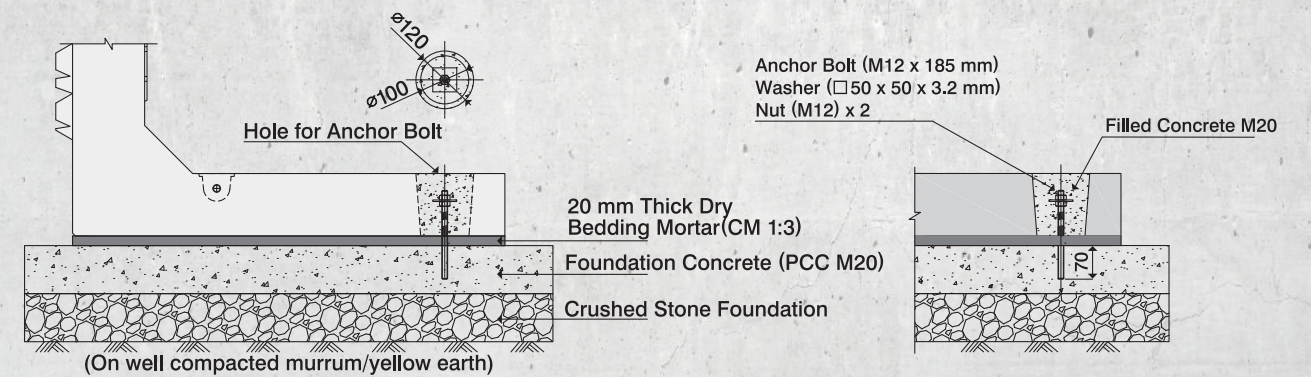

ANCHOR BOLT DETAIL

Note: The anchor bolts should be firmly fitted using chemical anchors so that they don't come out of the foundation.